

MECHANICAL ENGINEERING

Understanding applications, uses key to solenoid valve selection

By David Zdobinski, William Mudd, and Gregory Byrne

ASCO Valve, Inc.

Recent advancements in solenoid valve technology have expanded their scope of applications, while improving performance and reducing costs. To select the right valve for a given task, users should understand valve characteristics, consider critical factors, and be aware of some common problems and solutions in solenoid valve selection and maintenance.

A solenoid valve is an electro-mechanical device which, when energized or de-energized, either opens or closes a valve orifice. It's designed to control the flow of air, water, oil, gas, steam — practically any liquid or gaseous substance.

Valve selection starts by considering which operating type best suits your application's needs. Direct-acting valves open or close orifices by direct action of the core; pilot-operated valves for larger lines or higher pressures supplement this direct action by utilizing line pressure to open larger orifices while keeping solenoid size small. Normally closed valves open when energized and close when de-energized; normally open valves reverse this action.

Two-way solenoid valves have one inlet and one outlet pipe connection and are available normally open or closed. Three-way valves have three connections and two orifices and are available as normally open, normally closed, or universal (can be employed as either normally open or normally closed). Common applications include alternately applying pressure to and exhausting pressure from control valves, single-action cylinders, or actuators. Four-way valves use four or five pipe connections (one pressure, two cylinder, one or two exhausts) to operate double-acting cylinders or actuators.

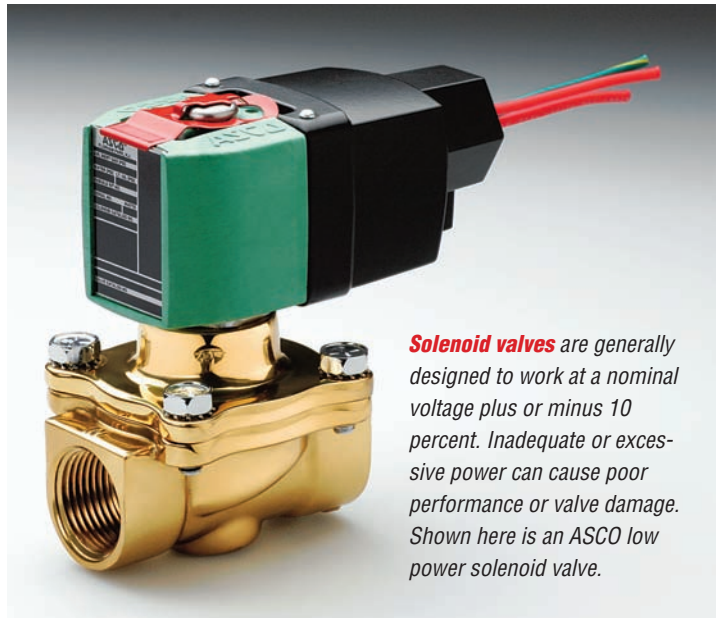

Solenoid valves are generally designed to work at a nominal voltage plus or minus 10 percent. Inadequate or excessive power can cause poor performance or valve damage. Shown here is an ASCO low power solenoid valve.

Common applications and issues

The solenoid valve is the most efficient means of automatic flow control for many liquids and gases. It requires the least plumbing, wiring, expense, and effort. By contrast, many ball valve installations, for instance, require not just a ball assembly but an actuator and a solenoid valve.

Users must consider the basic factors of valve type, electrical operation, flow medium, valve size, line pressure, ambient atmosphere, operating temperatures, required

voltage, and options such as special solenoid enclosures. Some of the most common issue that arise:

Over-rating pressure. A higher pressure rating does not mean a better valve. In fact, you should specify a valve whose specification most closely match the operating conditions of the specific application.

Not only may any higher rating waste money; it can actually impair valve operation, due to insufficient pressure drop (see below) or other problems.

Two-way, not bidirectional. Two-way valves are suitable for flow in one direction only. Install them to handle flow only in the direction indicated by the manufacturer; otherwise, operation may be unreliable or impossible.

Contaminated media. Contamination of line media is among the most common causes of solenoid valve problems. Most valves are designed for use with clean media; consult manufacturer's recommendations for any exceptions.

If possible, install valves with their solenoids in a vertical position to prevent accumulation of foreign matter in core tubes. If there's a chance of contamination, install a filter

or strainer upstream of the valve inlet and make routine maintenance, based on the actual application and service history, a priority.

Undervoltage/overvoltage. Solenoid valves are generally designed to work at a nominal voltage plus or minus 10%.

If your power supply is inadequate, undervoltage may cause failure of the valve to open or close, excessive noise, chattering and reduced life. (Check for adequate voltage by energizing the coil and listening for the click as the core contacts the plugnut.) Overvoltage will cause overheating, premature solenoid failure and reduced life.

Incorrect capacity. Oversizing a valve results in unnecessary expense, and both oversizing and undersizing can result in substandard performance. Factors such as orifice size and valve configuration are combined into the flow coefficient, or Cv. Calculate the Cv required for your application, or consult the valve manufacturer.

Improper replacement in OEM equipment. Many solenoid valves in OEM products are constructed for specific media and service. Unsuitable replacements can

Solenoid control valve troubleshooting guide

<i>Problem</i>	<i>Possible Cause</i>	<i>Possible Solution</i>
Valve will not operate when valve circuit is energized (direct-acting valve)	Low voltage or no voltage to solenoid coil	Check voltage at coil; voltage should be at least 85 percent of nameplate rating.
	Burned out coil	See "Coil Failure" below.
	Foreign matter jamming core in core tube	Clean valve; install strainer close to valve inlet.
	Binding core or damaged core tube	Replace parts.
	Excessive fluid pressure	Reduce pressure to valve nameplate pressure rating or install suitable valve.
Valve will not operate when valve circuit is energized (pilot-operated valve)	Same causes and solutions as for direct-acting valve, plus:	
	Low pressure drop across valve	Valve might be oversized; replace valve with one having a smaller orifice. Increase pressure, one having a smaller orifice. Increase pressure, if possible.
	Ruptured diaphragm or piston ring	Replace damaged parts.
	Plugged or restricted pilot orifice	Clean valve and pilot orifice.
Valve will not close or shift when valve circuit is de-energized (direct-acting valve)	Coil not de-energized	Check electrical control circuit.
	Foreign matter jamming core in core tube	Clean valve; install strainer close to valve inlet.
	Damaged disc or seat causing internal leakage	Replace with new parts.
	Binding core or damaged core tube	Replace with new parts.
	Damaged spring	Replace with new spring. Never elongate or shorten spring.
Valve will not close or shift when valve circuit is de-energized (pilot-operated valve)	Same causes and solutions as for direct-acting valve, plus:	
	Plugged bleed orifice	Clean orifice.
	Damaged pilot seat or pilot disc	Replace with new parts.
	Damaged diaphragm or piston	Replace with new parts.
	Insufficient pressure drop across the valve	Valve might be oversized; replace valve with one having a smaller orifice. Increase pressure, if possible.
	Dirt or foreign matter is lodged on seat	Replace valve body or install new valve; install suitable strainer close to inlet of valve.
Coil failure	Overvoltage	Check voltage at coil; voltage must conform to nameplate rating.
	Damaged core or core tube causing inrush current to be drawn continuously	Check for damaged core and core tube, or damaged spring. Check for scale or foreign matter on the core or inside the core tube.
	Foreign matter jamming core in core tube and causing inrush current to be drawn continuously.	Clean thoroughly and replace any damaged parts.
	Excessive fluid pressure causing inrush current to be drawn continuously	Reduce pressure or install suitable valve.
	Excessive ambient or fluid temperature	Class A coils are limited to ambient temperatures of 77 F. For temperatures up to 167 F, use Class F coils; for temperatures up to 212 F, use Class H.
	Missing solenoid parts	Install missing solenoid housing and other metal parts or properly install incorrectly assembled metal parts. The housing and other metal parts form part of the magnetic circuit and are required to provide the impedance needed to limit current draw.
	Moisture inside solenoid enclosure	Waterproof the entrance conduit to prevent entry of moisture. If valve is mounted outdoors, check to see that enclosure is weatherproof and that gaskets are in good condition; use appropriate sealant when required. If general-purpose enclosure is used in a damp or humid atmosphere, use watertight, molded coils.

bring reduced valve life, damage to the equipment, or even personal injury. Always consult the OEM's maintenance instructions, or contact the technical support group of the valve manufacturer with application details.

Insufficient pressure drop. Another common problem arises because many solenoid valves rely on a pressure drop between inlet and outlet (or between inlet and exhaust in the case of three-way and four-way valves) for valve opening or closing. Below the specified minimum operating pressure differential, the valve may function erratically, or not at all.

When specifying a valve, always make sure it can operate with the minimum (and maximum) pressure differential it will see in service. Pay special attention to restrictions in your system such as speed controls or regulators, which may reduce pressure below this critical differential.

Wrong choice of electrical operation. Consider whether your application requires a specific electrical option. Basic solenoid valves provide simple on/off electrical control. Manual reset models add a manual capability for emergency use. Intrinsically safe valves use extremely low power to avoid sparks in explosive atmospheres.

Unsuitable materials of construction. Be sure to select a valve with materials of construction suitable for your application. For steam, hot water, potable water, corrosives, or cryogenic liquids, make sure your valve has the appropriate rating. For example, don't employ an air valve to control fuel where a combustion valve is required.

Special valves for difficult applications are available with stainless steel or plastic bodies and a variety of trim materials, including nitrile rubber, neoprene, ethylene propylene, FKM, or PTFE.

Atmosphere issues. Solenoid valves for hazardous or explosive atmospheres employ features designed to prevent sparks or unacceptably high solenoid temperatures. These include special solenoid enclosures, thermal fuses, low power solenoids or air operators in place of solenoids.

Power availability issues. Solenoid valves are avail-

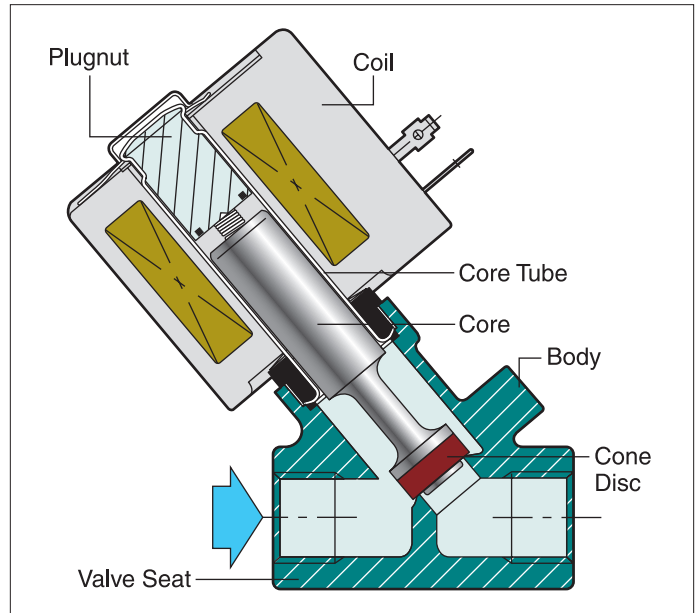

Two-way solenoid valves have one inlet and one outlet pipe connection and are not bidirectional. They are suitable for flow in one direction only.

able for almost any ac or dc power supply. Be sure the valve selected is suitable for the power source available. Note that because of differences in internal construction, ac valves cannot be converted to dc nor dc to ac by changing the coil only.

New developments

As one of industry's most ubiquitous instruments, the solenoid valve is being applied to new uses every day.

Specialty offshore pilot valves that draw power from solar panels are used in offshore oil platforms. Others models being introduced in process plants offer bus communications via DeviceNet, Profibus, and Foundation Fieldbus

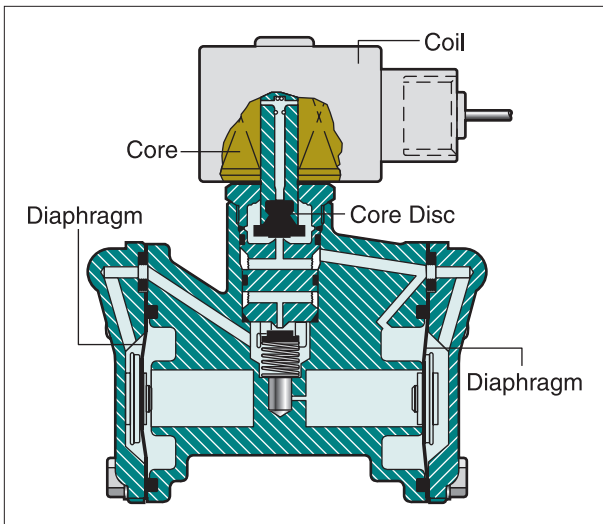

Three-way valves have three connections and two orifices and are available as normally open, normally closed, or universal, whereby they can be employed as either normally open or normally closed.

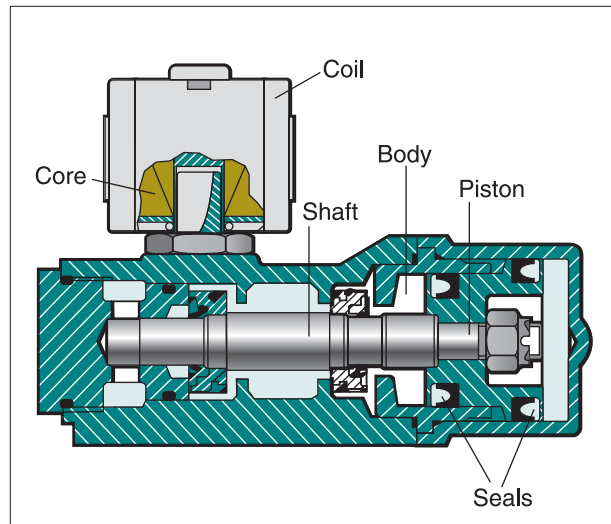

Four-way valves use four or five pipe connections – one pressure, two cylinder, one or two exhaust – to operate double-acting cylinders or actuators.

for fully networkable control.

One recent design defines a new category, the voltage-ranging solenoid valve. It draws ultra-low power (only 2 watts) and incorporates integrated electronics. This allows for dc pressure ratings at a level formerly only available with traditional ac valves.

Another long-wearing design is increasingly popular among users to provide very high flow rates, and handle corrosive or contaminated media, light slurries, steam, or other difficult media. These auxiliary-piloted, angle-body piston valves are ideal where media would not be suitable for the internal workings of a traditional solenoid valve. These

rigorous applications can be found anywhere from commercial laundries to industrial process plants. 

TheBottomLine...

- Avoid common misapplication errors for more reliable performance and longer valve life.
- Don't get more — or less — of a valve than your application needs
- New models allow handling of more varied and aggressive fluids, lower power usage, networkability, and more.
- David Zdobinski is senior engineering manager, William Mudd is manager of technical services and Gregory Byrne is service manager for ASCO Valve, Inc., Florham Park, NJ.

Posted from Plant Engineering, June 2006. Copyright © Reed Business Information, a division of Reed Elsevier, Inc. All rights reserved.

Page layout as originally published in Plant Engineering has been modified.

#1-17820636 Managed by Reprint Management Services, 717.399.1900. To request a quote online, visit www.reprintbuyer.com



info-valve@asco.com
50 Hanover Rd., Florham Park, NJ 07932, USA
973-966-2000
www.ascovalve.com